

SkyLine Pro Skyline Pro Gas Boilerless Combi Oven 61 120V

ITEM # _____

MODEL # _____

NAME # _____

SIS # _____

AIA # _____



219905 (ECOG61C3O30)

SkyLine Pro Combi Boilerless Oven with digital control, 6x1/1GN, gas, programmable, automatic cleaning, spray gun, 3-glass door and IoT module - 120V US

Short Form Specification

Item No. _____

**Replaces 219960

- Combi oven with digital interface with guided selection.
- Boilerless steaming function to add and retain moisture.
 - OptiFlow air distribution system to achieve maximum performance with 5 fan speed levels.
 - SkyClean: Automatic and built-in self cleaning system. 4 automatic cycles (short, medium, intensive, rinse).
 - Cooking modes: Programs (a maximum of 100 recipes can be stored); Manual; EcoDelta cooking cycle.
 - Automatic backup mode to avoid downtime.
 - USB port to download HACCP data, programs and settings
 - Connectivity for real time access, remote software update, HACCP, recipe and energy management (optional)
 - Single sensor core temperature probe.
 - Triple-glass door with double LED lights line.
 - Stainless steel construction throughout.
 - Supplied with n.1 tray rack 1/1 GN, 2 1/2 inches pitch.

Main Features

- SkyClean: Automatic and built-in self cleaning system with 4 automatic cycles (short, medium, intensive, rinse).
- Instant steam generator: Boilerless steaming function to add and retain moisture for high quality, consistent cooking results. Automatic moistener (11 settings)
- Dry hot convection cycle (77 °F - 575 °F/25°C - 300 °C): ideal for convection cooking.
- Short cleaning cycle: optimized cleaning cycle with a duration of just 33 minutes, improving efficiency and reducing downtime.
- 6-point multi sensor core temperature probe for maximum precision and food safety (optional accessory).
- EcoDelta cooking: cooking with food probe maintaining preset temperature difference between the core of the food and the cooking chamber.
- Programs mode: up to 100 recipes can be stored in the oven's memory, to recreate the exact same recipe at any time. 4-step cooking programs also available.
- OptiFlow: air distribution system to achieve maximum performance in chilling/heating evenness and temperature control thanks to a special design of the chamber.
- Reversible Fan: 5 speed fan levels from 300 to 1500 RPM with reverse rotation for optimal evenness. Fan stops in less than 5 seconds when door is opened.
- Single sensor core temperature probe included.
- Automatic cool-down and pre-heat function
- Back-up mode: self-diagnosis is automatically activated if a failure occurs to avoid downtime.
- Electrolux Professional recommends the use of treated water to guarantee optimal cooking results and extend the life of the appliance. Check local water condition to select the appropriate water filter. More info available on the website.

Construction

- Triple thermo-glazed door: with 2 hinged inside panels for easy cleaning and double LED lights line.
- Seamless hygienic internal chamber with all rounded corners for easy cleaning.
- 304 AISI stainless steel construction throughout.
- Front access to control board for easy service.
- IPX 5 spray water protection certification for easy cleaning.

Sustainability

- Human centered design: with 4-star certification for ergonomics and usability.
- Door handle: ergonomic wing-shaped design for hands-free door opening with elbow, to allow simple trays management (Registered Design at EPO EM003143551).
- Energy Star 2.0 certified product.
- Sustainability: The outer cardboard packaging is made from 70% recycled materials and FSC*-certified paper, printed with eco-friendly, water-based ink to support sustainability and environmental responsibility (*Forest

APPROVAL: _____

Stewardship Council is the world's leading organization for sustainable forest management).

- Triple-glass door minimize your energy loss.* *Approx. -10% of idle energy consumption in convection based on test in compliance with ASTM Standard F2861-20
- Save energy, water, detergent and rinse aid with SkyClean green functions.
- C22 and C25 detergents are formulated without phosphates and phosphorus (C25 is also maleic acid-free), making them safe for both the environment and human health.

Included Accessories

- 3 of Single 304 stainless steel grid (12" x 20") PNC 922062

Optional Accessories

- Water filter with cartridge and flow meter for 6 & 10 GN 1/1 ovens (low-medium steam usage - less than 2hrs per day full steam) PNC 920004
- Water filter with cartridge and flow meter for medium steam usage PNC 920005
- Caster kit for base for 61, 62, 101 and 102 oven bases only PNC 922003
- Pair of half size oven racks, type 304 stainless steel PNC 922017
- Chicken racks, pair (2) (fits 8 chickens per rack) PNC 922036
- Single 304 stainless steel grid (12" x 20") PNC 922062
- Stainless steel 304 grids (GN ½) with spikes, fits 4 chickens PNC 922086
- External side spray unit PNC 922171
- Baguette tray, made of perforated aluminum, silicon coated, 16" x 24" PNC 922189
- Perforated baking tray, made of perforated aluminum, 16" x 24" PNC 922190
- Baking tray, made of aluminum 16" x 24" PNC 922191
- Pair of frying baskets PNC 922239
- Pastry grid 16" x 24" PNC 922264
- Double-click closing catch for oven door PNC 922265
- Grid for whole chicken 1/IGN (8 per grid - 2.6 lbs each) PNC 922266
- Grease collection tray (4") for 61 and 101 ovens PNC 922321
- Kit universal skewer rack & (4) long skewer ovens (TANDOOR) PNC 922324
- Universal skewer pan for ovens (TANDOOR) PNC 922326
- Skewers for ovens, (4) 24" long (TANDOOR) PNC 922327
- Grease collection tray (1 1/2") for 61 and 101 ovens PNC 922329
- Smoker for ovens PNC 922338
- Multipurpose hook PNC 922348
- 4 FLANGED FEET FOR 61,62,101,102 OVENS - 2" 100-130MM PNC 922351
- Grid for 8 whole ducks (1.8KG, 4LBS) - GN 1/1 PNC 922362
- HOLDER FOR DETERGENT TANK - WALL MOUNTED PNC 922386
- USB SINGLE POINT PROBE PNC 922390

- 4 SERVICE FEET FOR 6&10 GN OVENS, 100MM - MARINE PNC 922394
- IoT module for SkyLine ovens and blast chiller/freezers PNC 922421
- Connectivity router (WiFi and LAN) PNC 922435
- STEAM OPTIMIZER PNC 922440
- Grease Collection Kit for Oven Cupboard Base GN 1/1-2/1 (trolley with 2 tanks, open/close device for drain) PNC 922450
- GREASE COLLECTION KIT FOR OVEN OPEN BASE GN 1/1-2/1 (2 TANKS, OPEN/CLOSE DEVICE FOR DRAIN) PNC 922451
- GREASE COLLECTION KIT FOR OVENS GN 1/1-2/1 (2 PLASTIC TANKS, CONNECTION VALVE WITH PIPE FOR DRAIN) PNC 922452
- 6 Tray Rack with wheels, Half Sheet Pans, 2 ½" (65mm) pitch for 61 ovens and blast chillers PNC 922600
- 5 Tray Rack with wheels, Half Sheet Pans, 3" (80mm) pitch, for 61 ovens and blast chillers PNC 922606
- Bakery/pastry tray rack with wheels 400x600mm for 6 GN 1/1 oven and blast chiller freezer, 80mm pitch (5 runners) PNC 922607
- Slide-in rack with handle for 61 and 101 combi oven PNC 922610
- Open base with tray support for 61 & 101 combi oven PNC 922612
- Cupboard base with tray support for 61 & 101 combi oven PNC 922614
- HOT CUPBOARD BASE WITH TRAY SUPPORT FOR 61 AND 101 OVEN HALF SHEET PANS (12" X 20") PNC 922615
- External connection kit for detergent and rinse aid PNC 922618
- Stacking kit for gas 61 oven placed on gas 61 oven PNC 922622
- Stacking kit for gas 61 combi oven placed on gas 101 combi oven PNC 922623
- Trolley for slide-in rack for 61 and 101 combi oven and blast chiller freezer PNC 922626
- Trolley for mobile rack for 61 on 61 or 101 combi ovens PNC 922630
- RISER ON FEET FOR STACKED 2X6 GN 1/1 OVENS OR 6 GN 1/1 OVEN ON BASE PNC 922632
- Riser on wheels for 2 stacked 61 combi ovens, height=250mm (9 6/7in) PNC 922635
- Stainless steel drain kit for all oven sizes (61, 62, 101,102, 201,202)- dia=50mm (2") PNC 922636
- Plastic drain kit for all oven sizes (61, 62, 101,102,201, 202), dia=50mm (2") PNC 922637
- Wall support for 61 oven PNC 922643
- Dehydration tray, (12" x 20"), H=2/3" PNC 922651
- Flat dehydration tray, (12" x 20") PNC 922652
- Bakery/pastry rack kit for 6 GN 1/1 oven with 5 racks 400x600mm and 80mm pitch PNC 922655
- Stacking kit for gas 6 GN 1/1 oven placed on 7kg and 15kg crosswise blast chiller freezer PNC 922657
- Heat shield for stacked ovens 61 on 61 combi ovens PNC 922660

- Heat shield for stacked ovens 61 on 101 combi ovens PNC 922661
- Heat shield for 61 combi oven PNC 922662
- Kit to convert from natural gas to LPG PNC 922670
- Kit to convert from LPG to natural gas PNC 922671
- Flue condenser for gas oven PNC 922678
- Fixed tray rack for 6 GN 1/1 and 400x600mm grids PNC 922684
- Kit to fix oven to the wall PNC 922687
- 4 adjustable feet for 61,62 & 101,102 combi ovens, 100-115mm (5 9/10in -7 9/1in) PNC 922688
- Tray support for 61 & 101 oven base PNC 922690
- 4 adjustable feet with black cover for 61,62 & 101,102 combi ovens, 150-200mm (5 9/10in -7 9/1in) PNC 922693
- Detergent tank holder for open base PNC 922699
- Bakery/pastry runners 400x600mm for 6 & 10 GN 1/1 oven base PNC 922702
- Wheels for stacked ovens PNC 922704
- Chimney adaptor PNC 922706
- Mesh grilling grid (12" x 20") PNC 922713
- Probe holder for liquids PNC 922714
- 4 high adjustable feet for 61,62 & 101,102 combi ovens, 230-290mm (9in - 11 2/5in) PNC 922745
- Tray for traditional static cooking, H=100mm (12" x 20") PNC 922746
- Double-face griddle, one side ribbed and one side smooth, 400x600mm PNC 922747
- TROLLEY FOR GREASE COLLECTION KIT PNC 922752
- WATER INLET PRESSURE REDUCER PNC 922773
- Extension for condensation tube, 37cm PNC 922776
- Non-stick universal pan (12" x 20" x 3/4") PNC 925000
- Non-stick universal pan (12" x 20" x 1 1/2") PNC 925001
- Non-stick universal pan (12" x 20" x 2 1/2") PNC 925002
- Frying griddle double sided (ribbed/smooth) 12" x 20" PNC 925003
- Aluminum combi oven grill (12" x 20") PNC 925004
- Egg fryer for 8 eggs (12" X 20") PNC 925005
- Flat baking tray with 2 edges (12" x 20") PNC 925006
- Baking tray for (4) baguettes (12" x 20") PNC 925007
- Potato baker GN 1/1 for 28 potatoes (12"X20") PNC 925008
- Non-stick U-pan (12" x 10" x 3/4") PNC 925009
- Non-stick U-pan (12" x 10" x 1 1/2") PNC 925010
- Non-stick U-pan (12" x 10" x 2 1/2") PNC 925011
- 6 NON-STICK U-PAN (12" X 20" X 3/4") PNC 925012
- 6 NON-STICK U-PAN (12"X20"X1 1/2") PNC 925013
- 6 NON-STICK U-PAN (12"X20"X2 1/2") PNC 925014

Front

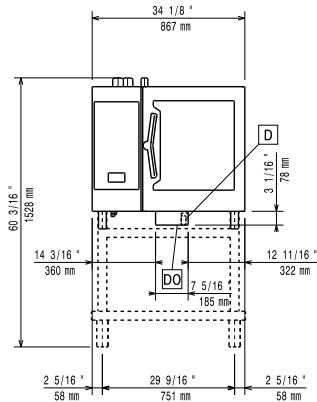

Side

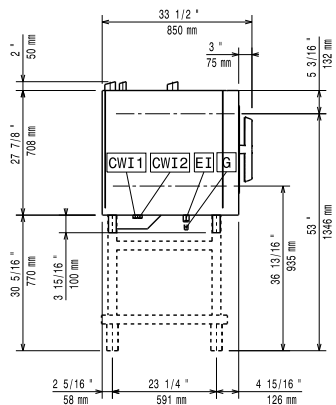

- CWI1** = Cold Water inlet **EI** = Electrical connection
CWI2 = Cold Water Inlet 2 **G** = Gas connection
D = Drain
DO = Overflow drain pipe

Top

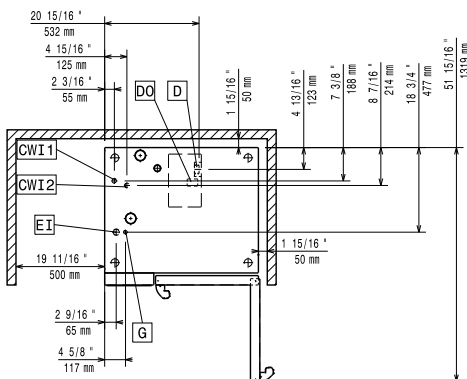

Electric

Supply voltage:	120 V/1 ph/60 Hz
Rated amps:	9.1 A
Electrical power, default:	1.1 kW

Gas

Gas power:	48109 Btu/hr
Gas Power:	14.1 kW
ISO 7/1 gas connection diameter:	1/2" MNPT

Water:

Pressure:	15-87 psi (1-6 bar)
Max inlet water supply temperature:	30 °C
Chlorides:	<10 ppm
Conductivity:	0 µS/cm
Drain "D":	50mm
Incoming Cold/hot Water line size:	3/4"

Capacity:

Max load capacity:	30 kg
Number and type of grids:	6 (GN 1/1)

Key Information:

Door hinges:	Right Side
External dimensions, Width:	34 1/8" (867 mm)
External dimensions, Depth:	30 1/2" (775 mm)
External dimensions, Height:	31 13/16" (808 mm)
Net weight:	263 lbs (119.5 kg)
Shipping height:	40 9/16" (1030 mm)
Shipping weight:	301 lbs (136.5 kg)
Shipping volume:	31.46 ft ³ (0.89 m ³)

Approvals

ENERGY STAR; ETL C&US; ETL SANITATION; ErgoCert 4*

ISO Certificates

ISO Standards:	ISO 9001; ISO 14001; ISO 45001; ISO 50001
----------------	---

Sustainability

Current consumption:	9.1 Amps
Water consumption:	13 lt/hr